



genesis
NP

NP38-12B
NP38-12R

*Sealed Rechargeable
Lead-Acid Battery*

12V, 38Ah

Specifications

- **NOMINAL VOLTAGE:** 12V
- **NOMINAL CAPACITY:**

20 hr. rate of	1.9A to 10.5V	38.0Ah
10 hr. rate of	3.5A to 10.5V	35.0Ah
5 hr. rate of	6.46A to 10.2V	32.3Ah
1 hr. rate of	22.8A to 9.60V	22.8Ah
- **WEIGHT (approx.):** 30 pounds (13.8 kgs.)
- **ENERGY DENSITY (20 hr. rate):** 1.30 WH/cubic inch (82.8 WH/liter)
- **SPECIFIC ENERGY (20 hr. rate):** 14.9 WH/pound (67.8 WH/kg)
- **INTERNAL RESISTANCE OF CHARGED BATTERY:** 8 milliohms (approx.)
- **MAXIMUM DISCHARGE CURRENT WITH STANDARD TERMINALS:** 150 amperes
- **MAXIMUM SHORT-DURATION DISCHARGE CURRENT:** 500 amperes
- **OPERATING TEMPERATURE RANGE:**

CHARGE	5°F to 122°F
	(-15°C to 50°C)
DISCHARGE	-4°F to 140°F
	(-20°C to 60°C)
- **CHARGE RETENTION (shelf life) at 68°F (20°C):**

1 month	97%
3 months	91%
6 months	85%
- **LIFE EXPECTANCY:**

STANDBY USE	3 to 5 years
CYCLE USE (approx.):	
100% depth of discharge	250 cycles
50% depth of discharge	550 cycles
30% depth of discharge	1200 cycles
- **SEALED CONSTRUCTION:** Can be operated in any position without leakage.
- **STANDARD TERMINAL:** Bolt Terminal or Receptacle Terminal with Bolt
- **HOUSING MATERIAL:** Container and cover made from Flame Retardant ABS (UL94-V0/L.O.I.>28%)

Terminal

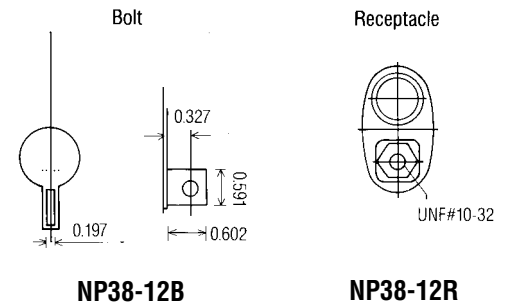

DIMENSIONS: INCHES

Dimensions

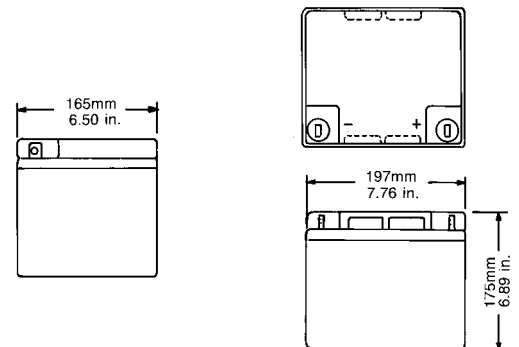

DIMENSIONS: MM (INCHES)

EnerSys[™]

Power/Full Solutions[™]



RECOGNIZED BY UL, File No. MH 16464

DISCHARGE CHARACTERISTIC CURVES AT 25°C (77°F)

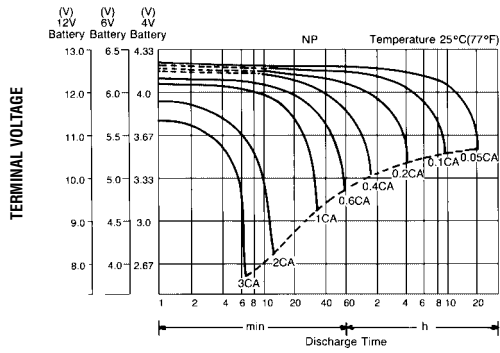

TEMPERATURE EFFECTS IN RELATION TO BATTERY CAPACITY

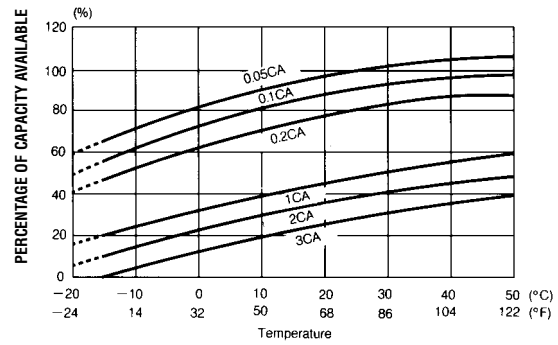

SELF DISCHARGE CHARACTERISTICS

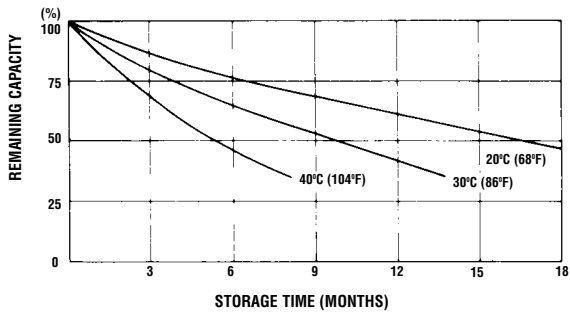

OPEN CIRCUIT VOLTAGE VS REMAINING CAPACITY

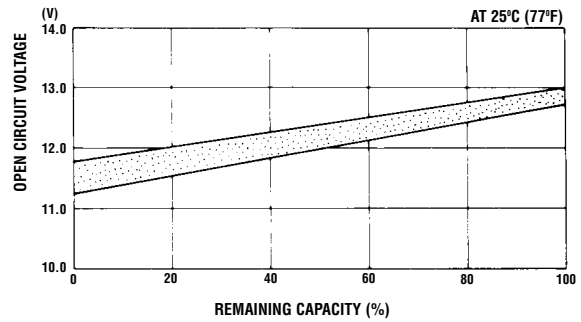

CYCLE SERVICE LIFE IN RELATION TO DEPTH OF DISCHARGE

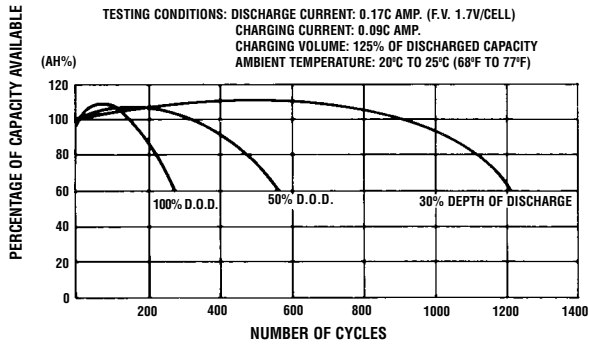

FLOAT SERVICE LIFE

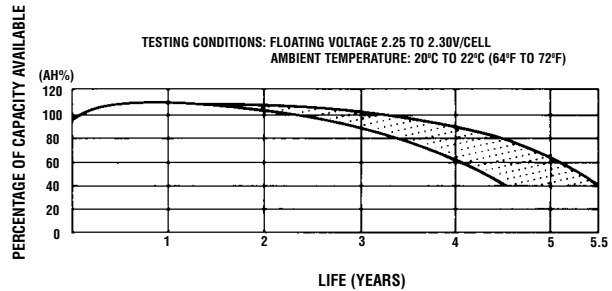

When the battery will be used by current in excess of 3C, consult with EnerSys, Inc. prior to use.

CHARGING METHODS (At 20°C)

Cycle use: Maximum charging current 9.5A
Charging voltage 14.4 to 15.0V
Standby use: Float charging voltage 13.50 to 13.80V

CAUTION

- Avoid short circuit
- Do not charge in a sealed container.