



Monolite

Model 12 SLA 50
12-volt, 50 Ah



FIAMM's **Monolite 12SLA50** valve-regulated, lead-acid battery is specifically designed to meet and exceed the exacting specifications of the Telecommunications industry. This "purpose-built" design philosophy, coupled with industry-leading manufacturing technology, ensures product consistency and reliable performance in a battery ideally suited to Telecommunications applications:

- 12-year plus design life
- Has passed the stringent Telcordia (Bellcore) 10-year accelerated life tests
- Good Energy Density
- Good Low-Rate Performance
- Easy Handling and Installation
- Safe Operation and Ease of Testing
- No Water Addition Needed

The FIAMM **Monolite 12SLA50** battery has a proven track record of exceptional performance in many parts of the network. With its traditional top-terminal design, it is ideally suited for applications utilizing roll-out trays or drawers such as Remote Terminals cabinets, Huts, CEV's, and Central Offices.

DESIGN FEATURES

- ▶ **Plates and Grids:** extra-thick plates with grids cast from high purity lead-calcium-tin alloy ensure long and reliable life
- ▶ **Separator:** microporous glass mat facilitates recombination and immobilizes the electrolyte
- ▶ **Internal Connections:** heavy-duty internal straps and through-the-partition cell connections minimize internal resistance for increased energy density
- ▶ **Terminals:** threaded post terminals with brass inserts provide for high conductivity and maximum torque retention
- ▶ **Post Seals:** state-of-the-art post seals prevent seepage over a wide temperature range
- ▶ **Safety Valve:** each cell has its own one-way valve that opens at 5 psi and closes at 3 psi to allow excess gas to escape in case of over-charging
- ▶ **Flame Arrestor:** lets excess gas out while preventing any errant spark or flame from entering the battery
- ▶ **Container and Cover:** made from thick-walled ABS plastic and designed for unsurpassed mechanical strength, the cases and covers have an LOI greater than 28% and meet the flame retardancy standards of UL 94 V-0
- ▶ **Handles:** handles integrated into the cover to aid in handling, installing and removing the batteries

STANDARDS COMPLIANCE

The 12SLA50 meets the requirements of the following industry standards:

- ▶ ANSI T1.330-1997
- ▶ British Standard BS 6290 Part 4
- ▶ British Standard 6334 method FV0
- ▶ Eurobat Guide - 12 years and longer "long life"
- ▶ IEC 707 FV0
- ▶ IEC 896 Part 2
- ▶ Telcordia (Bellcore) SR-4228
- ▶ Telcordia (Bellcore) TR-NWT-000766
- ▶ Telcordia (Bellcore) TR-NWT-000909
- ▶ Telcordia (Bellcore) TR-NWT-001200
- ▶ UL 1778
- ▶ UL 94 Class V-0
- ▶ UL Recognized

Telecommunications Standby Batteries



Monolite Model 12 SLA 50

1394788
07.02

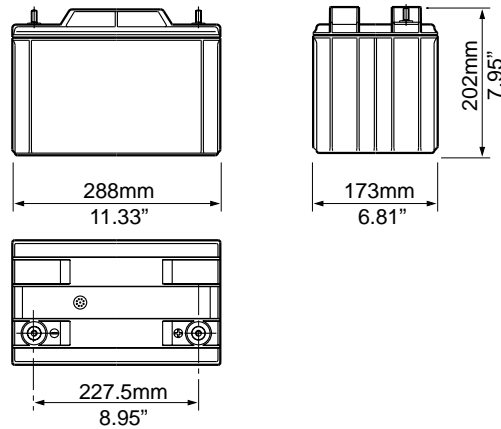

DISCHARGE AMPERES FOR 12 SLA 50 AT 77°F (25°C)

	HOURS										
	1	2	3	4	5	6	7	8	10	12	20
1.65	34.0	19.1	13.7	10.9	9.10	7.91	7.00	6.28	5.18	4.36	2.74
1.70	33.4	18.9	13.6	10.8	9.07	7.89	6.98	6.26	5.17	4.35	2.73
1.75	32.6	18.5	13.5	10.8	9.02	7.85	6.95	6.23	5.13	4.32	2.71
1.80	31.8	18.1	13.4	10.7	8.96	7.79	6.90	6.19	5.08	4.29	2.69
1.85	30.8	17.4	12.5	9.95	8.39	7.38	6.55	5.89	4.86	4.11	2.58
1.88	29.8	16.9	12.1	9.60	8.10	7.02	6.20	5.53	4.55	3.83	2.40

DISCHARGE WATTS PER CELL FOR 12 SLA 50 AT 77°F (25°C)

V/cell	HOURS										
	1	2	3	4	5	6	7	8	10	12	20
1.65	62.4	35.6	26.1	20.8	17.5	15.2	13.5	12.1	9.93	8.39	5.25
1.70	62.3	35.6	26.1	20.8	17.5	15.2	13.5	12.1	9.92	8.38	5.25
1.75	61.6	35.4	26.0	20.8	17.5	15.2	13.5	12.1	9.91	8.37	5.24
1.80	61.0	35.0	26.0	20.8	17.4	15.2	13.4	12.1	9.90	8.36	5.24
1.85	59.9	34.3	24.7	19.6	16.5	14.6	12.9	11.6	9.60	8.11	5.10
1.88	58.4	33.4	24.0	19.0	16.1	13.9	12.3	11.0	9.03	7.62	4.77

TECHNICAL SPECIFICATIONS

- ▶ **Capacities:** 50 AH at C8 to 1.75 VPC at 25°C
- ▶ **Recommended Float Voltage:** 13.56 V at 25°C
- ▶ **Temperature Compensation:** -15mV/°C
- ▶ **Maximum Charge Current:** 13 A
- ▶ **Self-Discharge at 77°F (25°C):** <2% per month
- ▶ **Short Circuit Current:** 2030 A
- ▶ **Internal Resistance:** 6 mohm
- ▶ **Weight:** 48.50 lb. (22.0 kg)
- ▶ **Terminals:** M8
- ▶ **Terminal Torque:** 65-70 in. lbs (7.3-8.0 Nm)



Telecommunications Standby Batteries